

Ozark Patrol Assembly Manual

Copyright – 2014



David Cripe NM0S
The 4 State QRP Group

Thank you for purchasing a Ozark Patrol kit. We hope you will enjoy building it and find it a fun addition to your shack.

Many radio hobbyists from a generation ago were introduced to shortwave radio by building and listening to inexpensive regenerative receiver kits from Radio Shack, Knight or Allied. Despite their simplicity, their regenerative circuits obtained surprising results from a just a couple of tubes or transistors, pulling in CW ham signals, or overseas broadcasts from Radio Moscow. Today, these old kits command impressive prices for those seeking to relive a bit of nostalgia. The 4SQRP Ozark Patrol radio was designed in homage to these simple sets of yesteryear, so that hobbyists of today can relive the experience of a regenerative receiver.

High quality, double sided, printed circuit board construction is used, with solder mask and silk screened component reference designators. A unique, construction technique is used in the Ozark patrol, called 'Pittsburg' construction, after the hometown of its inventor Joe, W0MQY. This method uses easy-to-handle through hole components in a modified surface mount construction technique, where the back copper layer of the board forms a complete ground plane shielding the circuitry against hand effects.

The Ozark Patrol can be constructed by beginners as well as experienced builders. Construction time is approximately 2 hours, depending on experience level.

First Steps

Before getting started with building the Ozark Patrol, take some time to organize and familiarize yourself with the parts provided and check them against the Bill of Material. Building over a cookie sheet is recommended to minimize parts being lost. If parts are missing in your kit, send an email to the kitter listed on the kit website <http://www.4sqrp.com/ozarkpatrol.php>. He will promptly provide replacements.

Schematic and parts-placement files are provided as part of documentation package. It is highly recommended to print a couple of copies for reference during construction. As you build, use a highlighter to mark off parts that have been soldered onto the PCB on one copy. When you think you are done, you can check that copy to verify that all of the parts have been installed.

Assembly

() Begin by winding L1, 20 turns of magnet wire wound tightly on the T50-2 toroid. Turns are counted as the number of times the wire passes through the center of the toroid.

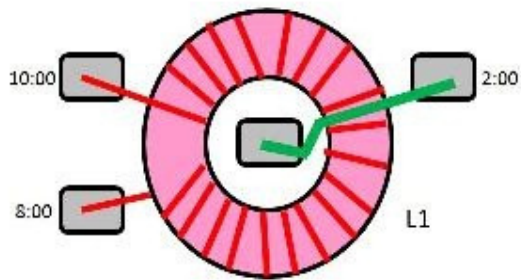

Figure 1: Winding diagram for L1

Make certain that the direction of the winding matches that of the diagram, with the start and stop of the windings close together. When the turns are completed, cut the ends of the wire to 0.25" from the outside of the toroid. Strip back the insulation from the ends of the wire. A preferred method is to use heat of a hot soldering iron to melt the insulation and tin the wire in a single operation. Sanding or scraping the insulation prior applying the soldering iron will help speed the tinning process.

() Cut a 1" piece of magnet wire, and strip and tin 1/4" from each end. Solder one end of this wire to the pad in the center of the L1 position on the PC board. Slide the wound toroid over this wire, and solder the other end of this wire to the solder pad at the right of the toroid.

() Solder the toroid winding coming up through the center of the toroid to the L1 solder pad at the 10 o'clock position. Solder the winding coming from the underside of the toroid to the L1 solder pad at the 8 o'clock position.

Next, let's mount the resistors. It is easiest to mount the small electrical components by bending their leads into a 'W' shape per the diagram, and to tin one of the solder pads on the board. Holding one of the ends of the component lead, move it into place and tack it down to the tinned pad. Then, solder the opposite pad, and re-solder the first pad to assure the quality of its solder joint. Finally, trim off the excess leads.

Mark off each resistor from the list as you proceed.

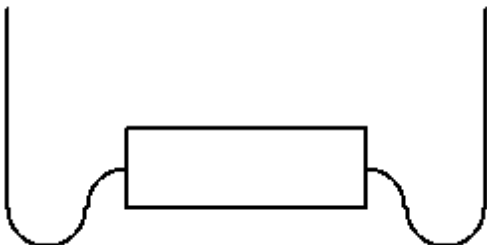

Figure 2: Lead preparation for mounting.

- () R1 4.7k yellow-violet-red
- () R2 4.7k yellow-violet-red
- () R3 56k green-blue-orange
- () R6 33k orange-orange-orange
- () R7 4.7k yellow-violet-red
- () R8 220 red-red-brown
- () R10 10k brown-black-orange
- () R11 1.0M brown-black-green

Mount the diodes. Pay attention to the polarity markings on the devices, which should correspond to the markings on the PC board.

- () D1 1N4001
- () D2 1N914
- () D3 1N914

Mount the capacitors. Pay attention to the polarity of the aluminum electrolytic capacitors. There is a band marked on their bodies corresponding to the negative terminal. The solder pad corresponding to the positive terminal of the capacitor marked on the PC board.

- () C2 0.047 ceramic 473
- () C3 470u electrolytic
- () C4 0.001 ceramic 102
- () C5 0.001 ceramic 102
- () C6 1.0u electrolytic
- () C7 470u electrolytic
- () C8 0.047 ceramic 473
- () C9 4.7p ceramic
- () C10 470u electrolytic



Figure 3: Gimmick Capacitor

Mount the transistors next. Notice the metal cans have a tab corresponding to the emitter terminal, which is marked on the PC board also.

- () Q1 2N3019
- () Q2 2N3019
- () Q3 2N3019

() Cut two, three inch pieces from the insulated hookup wire. Strip 1/4" of insulation from both ends of each piece. Locate the headphone jack and the audio transformer. Solder the two, three inch segments of hookup wire, and the secondary leads of the audio transformer into the terminals of the stereo jack per the diagram. Mount the transformer and jack to the PCB.

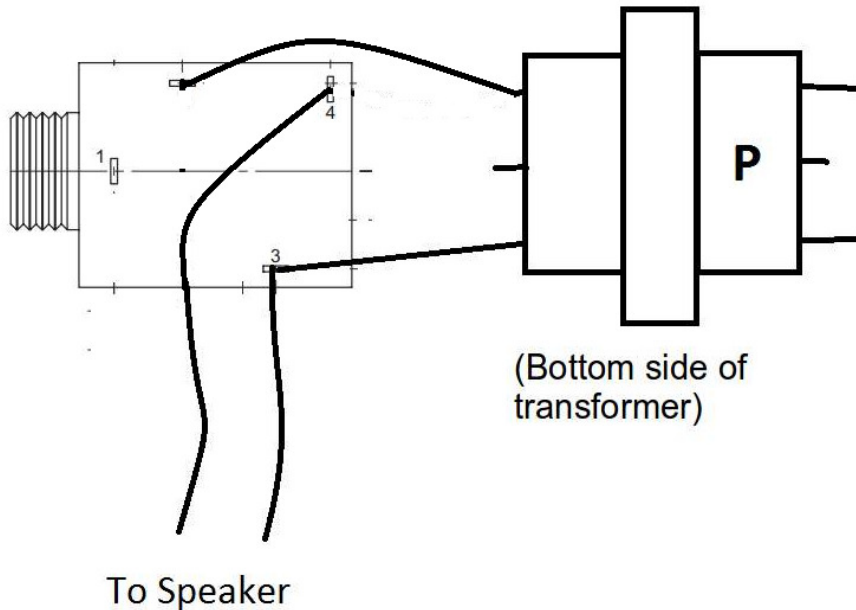

Figure 4: Audio Jack Connection

() Mount the speaker to the rear of the front panel using the four, 3/8" 6-32 screws, with washers and nuts on the back side over the holes in the corners of the speaker. Screw the mounting screws down only medium snug so that the frame of the speaker is not deformed.

Mounting the Variable Capacitor

() Locate the variable capacitor, C1. Holding it shaft-side down, clip off the four, long straps in each of the four upper corners. Mount the capacitor to the PCB using the two small screws so that the side with the three connection straps is oriented upward. Bend each of the straps so that they touch the solder pads, and trim off the excess length so that they do not extend past the solder pads. Solder into place.

() Screw the nylon spacer firmly into the shaft of the capacitor using the longer fine-threaded screw.

Mounting the Pots

() Locate the smaller two pots, R4 and R9. Remove their mounting hardware, and trial-

fit them into place. Gently bend their terminals into place to that they just touch the solder pads on the PCB. Mount these pots using the flat washer and nut on the front panel, and solder the terminals into place.

() Add C13, the 1.0u electrolytic capacitor to the terminals of R4 per the diagram.

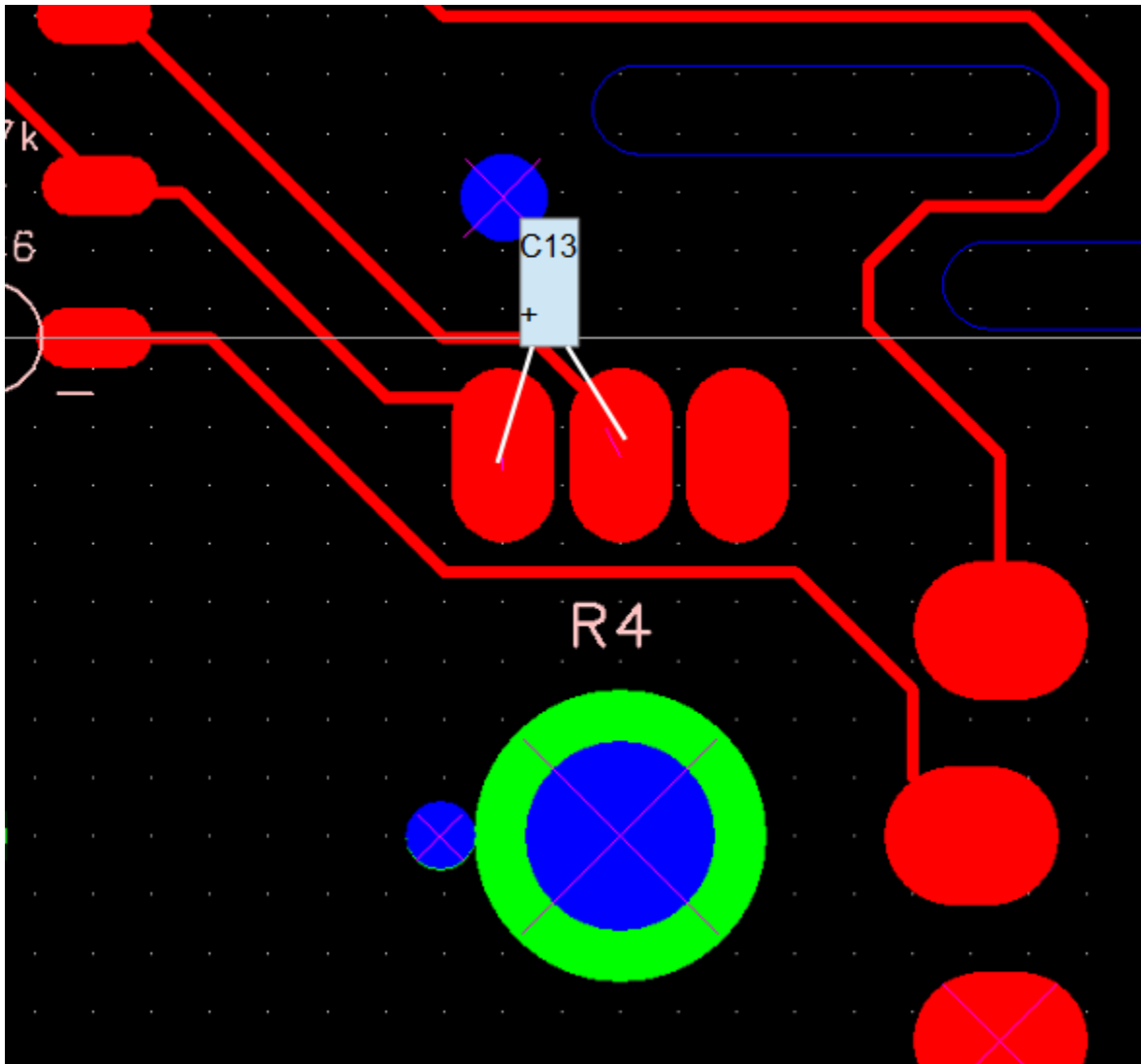

() Locate the larger pot, R5. The two terminals on the rear of the pot are the power switch. Mount as per R4 and R9. Cut and strip the ends of a two inch piece of insulated hookup wire and connect between one of the switch terminals and the pad on T1 labeled '+9v'.

() Install the band select switch SW2. Install capacitor C11, the 560p capacitor, between the upper terminal of the switch and the adjacent solder pad.

() Cut a 2 1/2" piece of insulated hookup wire, and strip the ends. Connect between the

lower contact of SW2, and the upper right solder pad of the variable capacitor C1

() Cut a 6" piece of insulated wire, and strip and tin 1/4" of insulation from the ends. Solder one end to the bottom solder pad of the variable capacitor C1.

() Cut a 6" piece of magnet wire, and strip and tin 1/4" insulation from ONE end. Solder this to the upper left solder pad of the variable capacitor C1.

() Take the battery holder and solder the black wire to the solder pad labeled '-9v' and solder the red wire to the open switch terminal on the back of the volume pot.

() Take the wooden breadboard base and attach the front panel to one edge using two wood screws.

() Attach the battery holder to the board using wood screws.

() Attach the two fahnestock clips to the rear edge of the board opposite the variable capacitor, using a flat washer and wood screws. Position them approximately 1" apart. Label one 'ANT' and the other 'GND'. Do not tighten down the screws yet.

() Place the end of the insulated hookup wire between the fahnestock clip and the washer of the 'GND' terminal. Tighten the screw.

() Cut a 2" piece of magnet wire. Strip the insulation from ONE end, and tin. Place tinned end between the fahnestock clip and flat washer of the terminal marked 'ANT'. Tighten screw.

() Make the antenna coupling gimmick capacitor C12 by loosely twisting about 1" of the magnet wire extending from the variable capacitor terminal and the wire extending from the 'ANT' terminal.



() Attach the four knobs to the shafts of the front panel controls.

Theory of Operation

The Ozark Patrol is a series of time-tested circuits that work together to obtain the maximum output from the fewest components. With only three transistors, the circuit is capable of receiving shortwave and amateur transmissions with microvolt sensitivity.

The heart of the receiver is the regenerative detector circuit surrounding Q1. Antenna signals are coupled into the tuning circuit L1a-C1 through the gimmick capacitor C12. The single turn secondary L1b couples some of the energy of the amplified Q1 output back to its input for positive feedback. The gain of the feedback is set by the Q1 bias, controlled by the base bias current, set by the REGENERATION pot, R4. When the tuned circuit is just at the threshold of oscillation the radio frequency signal can be amplified millions of times.

Capacitor C9 takes a minute amount of this amplified radio signal, and rectifies it through diodes D2 and D3. The detected audio signal is fed to the base of Q1, and is amplified further. This use of a single device as an amplifier of both radio and audio signals is called a 'Reflex Amplifier' and dates back to the vacuum tube days. The way it is implemented in this circuit, the reflex action also acts as an automatic gain control, tending to level out the variations in signal strength from one station to another.

The audio signal from Q1 is coupled through C6 to Q2 and Q3, a dual-stage audio amplifier, and output to the speaker or headphones through transformer T1.

Operation

A regenerative receiver works very differently from other receivers we may be familiar with. The receiver works best with the regeneration control set just at the threshold of oscillation, which makes tuning this radio a two-handed operation.

Insert six, AA cells into the battery holder. Connect a ground wire and an antenna. Turn the volume control fully clockwise to tune on the radio.

Rotate the REGENERATION control fully counterclockwise. You should notice a hiss from the speaker. With antenna and ground connected, rotate the main tuning control slowly from one end to another. You should notice many popping or chirping noises as signals are passed while tuning. Select one of the louder pops, and try to tune it in with the main tuning control. Gradually tune the REGENERATION control clockwise, while using the BANDSPREAD control to keep the signal tuned. There will be a point where the signal reaches maximum volume. You will find that for AM signals, less distortion of the signal will be had with the REGENERATION control slightly more

clockwise than this, and for SSB signals, more counter-clockwise. With practice, tuning in signals becomes second nature.

About the Gimmick Capacitors

A gimmick capacitor is a construction that may be unfamiliar to many builders, but dates back to the early days of radio. It is a simple way to make small-value adjustable capacitors.

In the Ozark Patrol, a gimmick capacitor is used for lightly coupling the antenna to the receiver. It is not critical in its value, but it does have an effect on the performance of the receiver. It can be increased in value by twisting tighter, and reduced by untwisting.

The antenna coupling capacitor C12 controls the amount of antenna signal coupled to the tuning circuit, and affects the selectivity of the receiver. Too much capacitance here reduces selectivity and limits the ability to select one station over another adjacent signal. Too little capacitance results in low signal levels and low volume. Experiment to find the best results.

Troubleshooting

In a radio this simple, there is very little to go wrong, and most problems have to do with soldering problems. Double check all solder joints, especially those to the magnet wire. Make sure all components are in the correct location, and in the correct orientation.

One frequent mistake that befalls builders of regenerative sets is getting the polarity of the primary or tickler winding backward. If there is no regeneration present, you may need reverse the primary windings.

You may also use circuit voltages to narrow down problem areas of the circuit. Measure the voltages with the REGENERATION control fully counter-clockwise:

Emitter (tab) Q1	0v
Base (middle) Q1	0.65v
Collector (can) Q1	3 to 5 volts
Base (middle) Q2	0.65v
Collector (can) Q2	3v
Emitter (tab) Q3	2.5v
Collector (can) Q3	8-9v

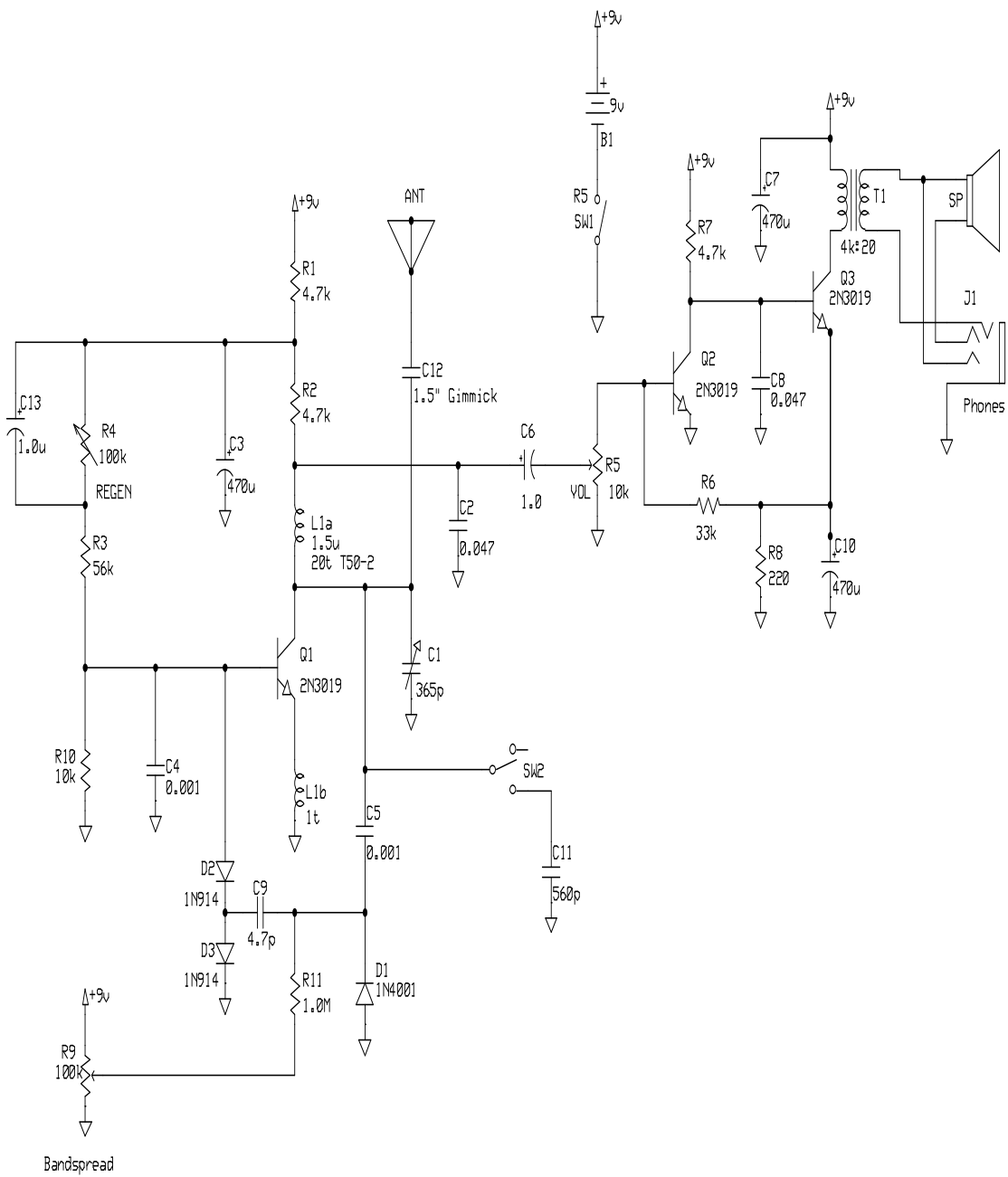

NMOS RADIO		
4SQRP Regen		
D. Cripe NMOS	Rev 1.1	Page #1 of 1
	07/22/2014	

Electrical Components

	Ref	Value	Code
()	C1	520p variable	
()	C2	0.047 ceramic	473
()	C3	470u electrolytic	470
()	C4	0.001 ceramic	102
()	C5	0.001 ceramic	102
()	C6	1.0u electrolytic	1.0
()	C7	470u electrolytic	470
()	C8	0.047 ceramic	473
()	C9	4.7p ceramic	
()	C10	470u electrolytic	470
()	C11	560p ceramic	561
()	C12	Gimmick – see instructions	
()	C13	1.0u electrolytic	
()	D1	1N4001	
()	D2	1N914	
()	D3	1N914	
()	J1	1/8" Stereo jack	
()	L1a,b	T50-2 toroid	
()	Q1	2N3019	
()	Q2	2N3019	
()	Q3	2N3019	
()	R1	4.7k yellow-violet-red	
()	R2	4.7k yellow-violet-red	
()	R3	56k green-blue-orange	
()	R4	100k pot	
()	R5	10k pot with switch	
()	R6	33k orange-orange-orange	
()	R7	4.7k yellow0violet-red	
()	R8	220 red-red-brown	
()	R9	100k pot	
()	R10	10k brown-black-orange	
()	R11	1.0M brown-black-green	
()	Speaker		
()	SW2	SPST	
()	T1	4k:20 audio	

Mechanical Components

	Qty	Description
()	7	6x 1/2" Wood Screw
()	2	Fahnestock Clips
()	1	6xAA Battery Holder
()	2	large knobs
()	2	medium knobs
()	1	PC Board Front Panel
()	1	pine plank
()	1	M2.6-12 screw
()	2	M2.6-4 screw
()	1	1/4" x 3/8" standoff
()	4	6-32x 3/8" screw
()	4	6-32 nut
()	7	#6 flat washer
()	4'	22 AWG magnet wire
()	6"	22 AWG hookup wire